

mardi 23 juin

Travail pour

les 7^{èmes} années

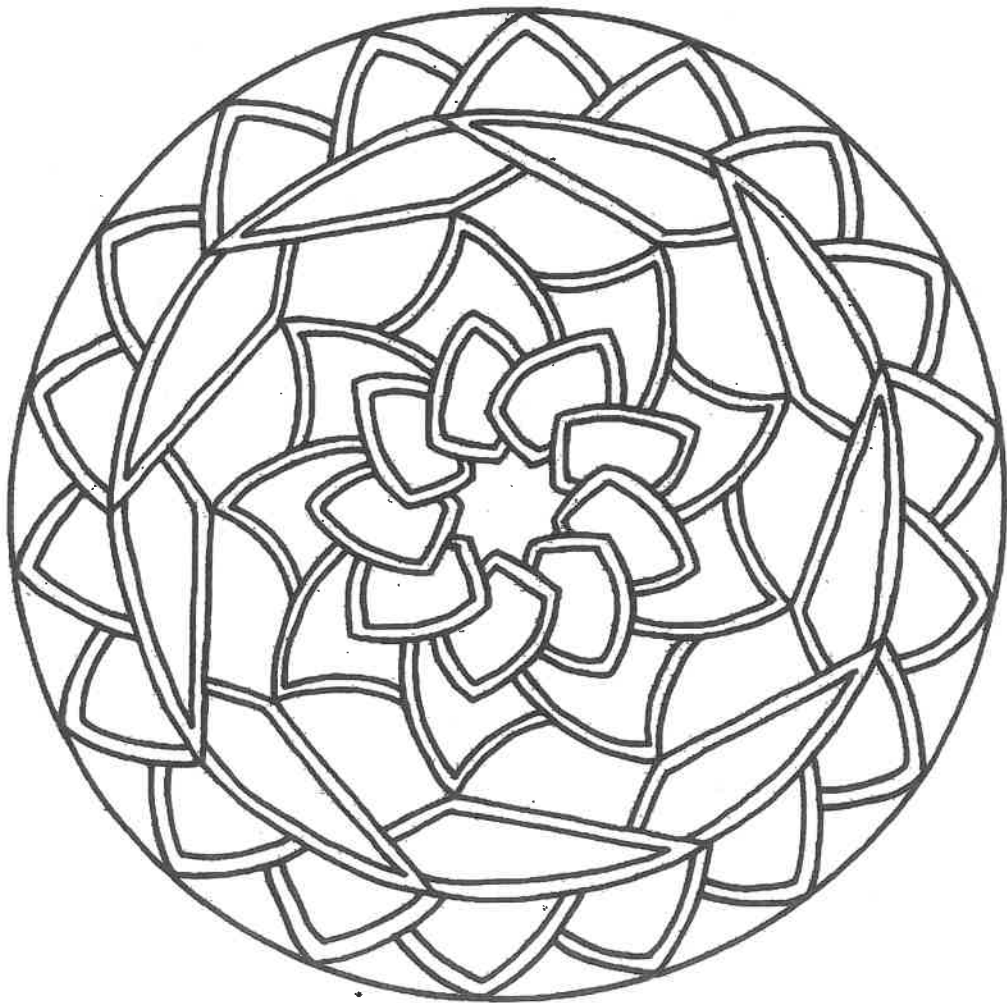

Programme de la journée du lundi 23 juin.

1. Reprise des devoirs.
2. Lecture : Farde 52.
3. Lecture : La lettre « n » : Discrimination visuelle et discrimination auditive (jeux).
4. Calcul : Découverte des dizaines : Le jeu des allumettes (But : Faire des paquets de 10).
5. Ecriture : La lettre « n » : Découverte minuscule et majuscule + feuille.
6. Spectacle via vidéoconférence : "Le tout petit monsieur" du Théâtre des Zygomars.
7. Lecture : Farde 53.
8. Calcul : Le jeu des allumettes : Exercices.
9. Lecture : La lettre « n » : Carnet (début).
10. Dessin : « Je dessine comment j'ai vécu le confinement » (prolongement du spectacle « Le tout petit monsieur »).
11. Journal de classe et explication des devoirs.

Devoirs pour le mardi 23 juin.

- Ecriture : n - N.
- Lecture : Farde 53.
- Calcul : Exercices (2 feuilles).
- Lecture : Terminer le carnet « n » (**SAUF** exercice n°20).

N

n

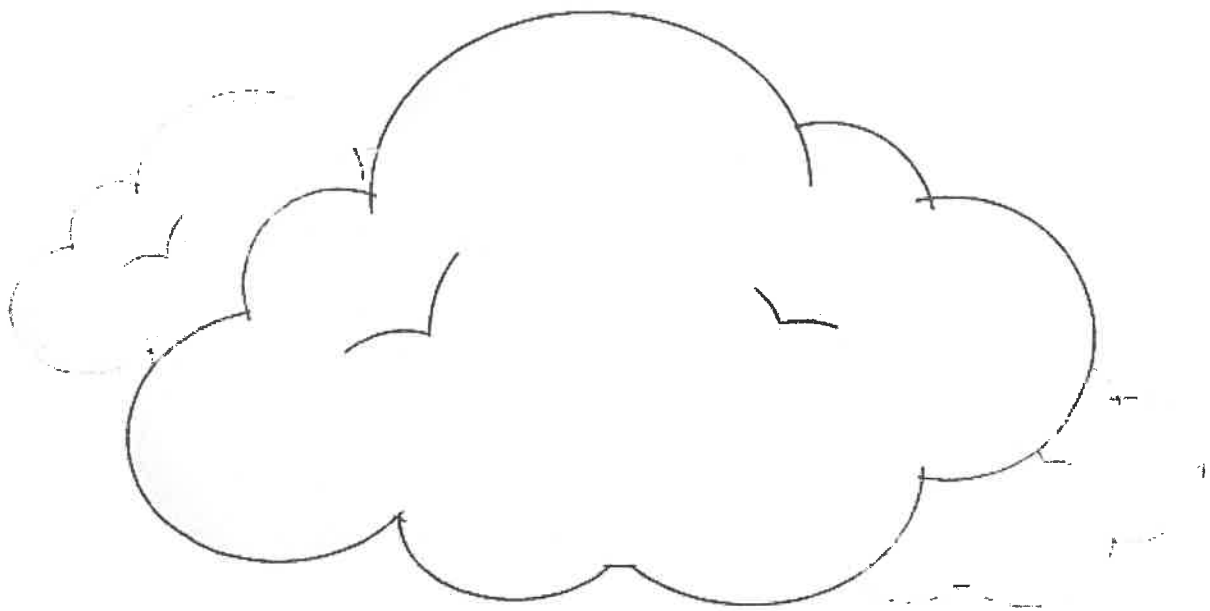

N

n

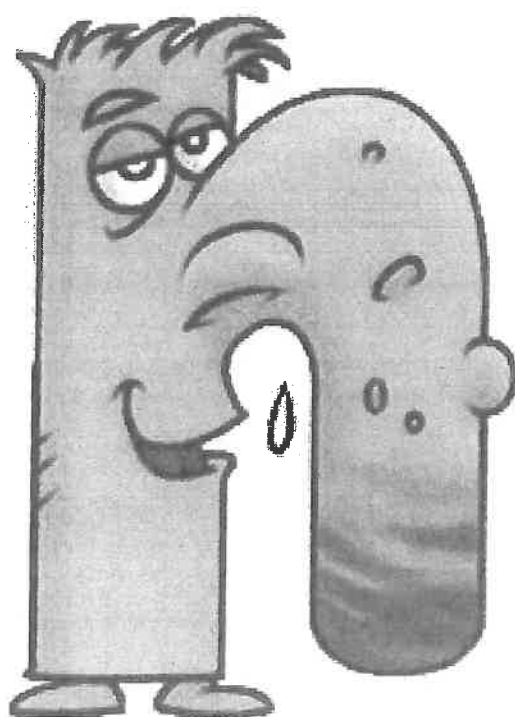



1. Noah_x forme un numéro de télé^fphone.
2. Nathan_x offre un canari à madame.
3. Sonia donne de la farine à Léonie.
4. Mellyna a amené un ananas_x et une banane.
5. Le cheval trotte derrière Marion.
6. Nathan_x a vu un navire à la mer.
7. Del^fphine joue des notes_x sur son piano.
- 8. Wendy et Marion lavent les fenê_xtres._x**
9. Nicolas_x a donné un domino à Simon.
- 10. Un animal a volé la nour_xriture sur la table.**
11. Nolan dîne avec des tartines_x et de la limonade.
- 12. Le mardi, nous all^sons à la natation.**

Prénom : _____



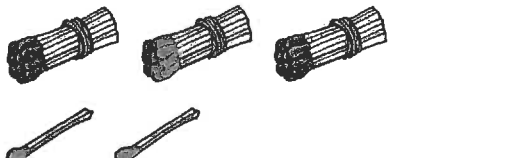
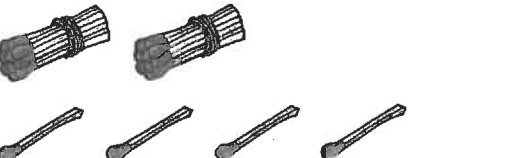
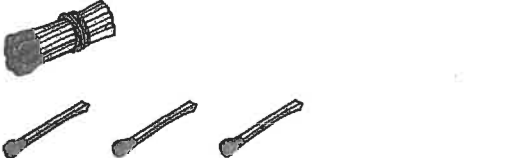
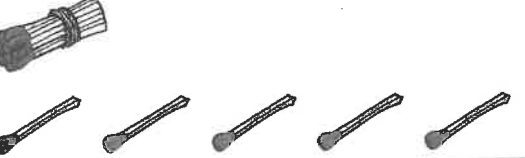

Date : _____



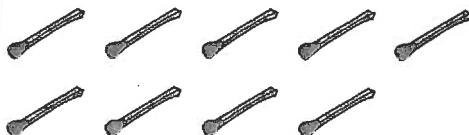

Le jeu des allumettes.

1. Ecris le nombre d'allumettes.





 <input style="width: 50px; height: 40px; margin-left: auto; margin-right: auto;" type="text"/>	 <input style="width: 50px; height: 40px; margin-left: auto; margin-right: auto;" type="text"/>
 <input style="width: 50px; height: 40px; margin-left: auto; margin-right: auto;" type="text"/>	 <input style="width: 50px; height: 40px; margin-left: auto; margin-right: auto;" type="text"/>
 <input style="width: 50px; height: 40px; margin-left: auto; margin-right: auto;" type="text"/>	 <input style="width: 50px; height: 40px; margin-left: auto; margin-right: auto;" type="text"/>

2. Entoure le matériel nécessaire pour former les nombres donnés.

18		
9		
24		

16		
11		

3. Ecris le nombre représenté.

	
	
	
	
	

Prénom : _____

Date : _____

La lettre n.

1. Colorie le dessin si tu entends n n.

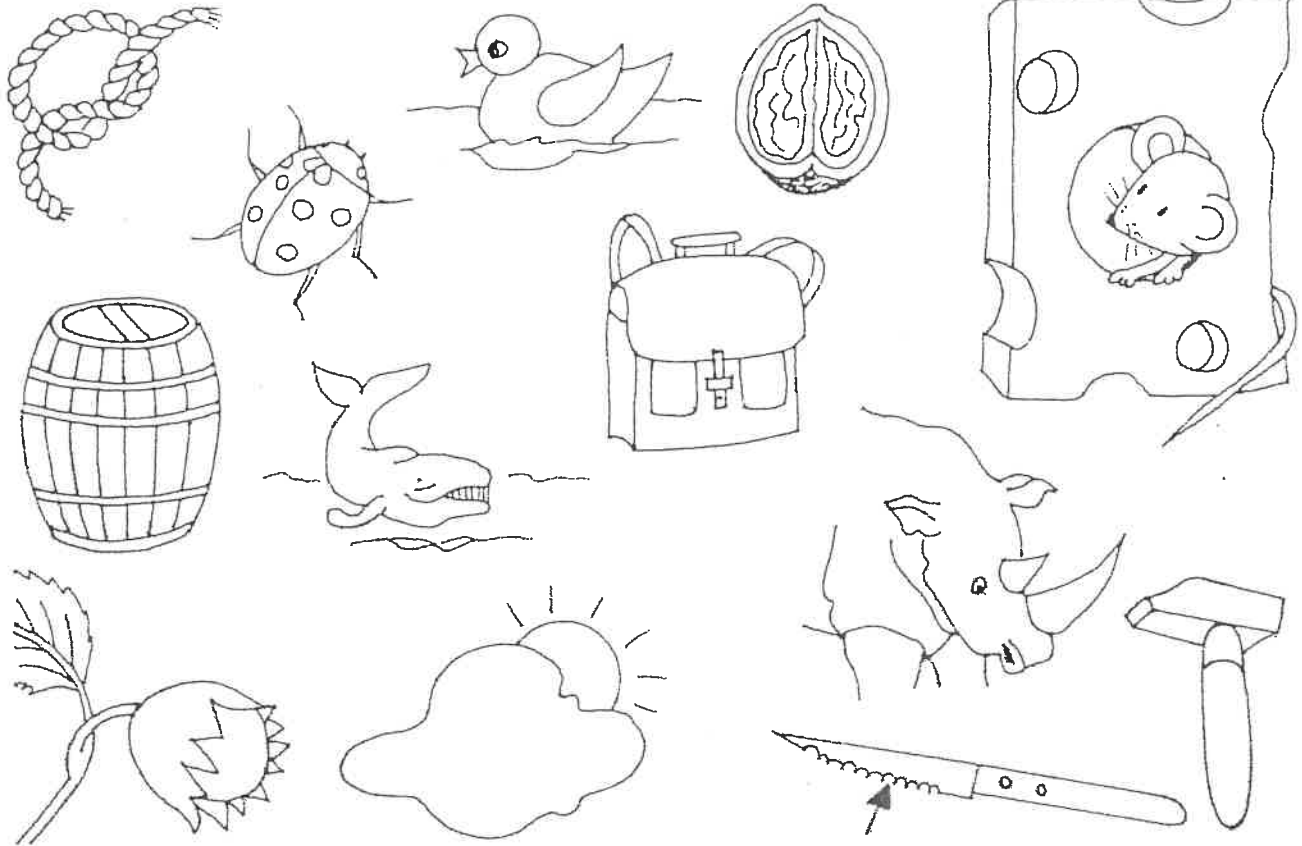

2.  Entoure les n n dans les mots.

livre	lune	maman	chapeau	sorcière
crayon	vent	mallette	dans	Saint Nicolas
forêt	arbre	écharpe	classe	renard
poupée	colle	plumier	tête	magie
marron	image	chien	feuille	potiron
formule	cou	orange	utile	cadeau
minute	soupe	serpent	recette	casserole
voiture	ciseaux	école	automne	minute

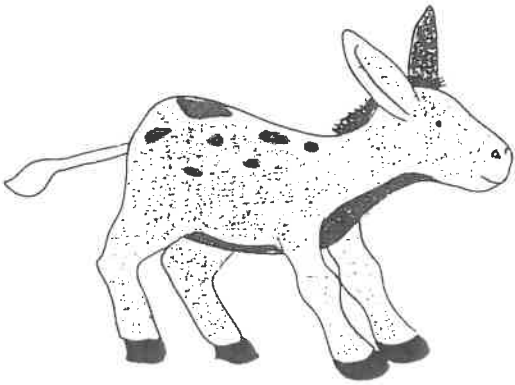

un âne

N n
n [n]

3. Lis.

na ni nu no né na ni a nu o no i ni u
nu i li ni o lo no a la na e le ne a

4. Lis les mots et colorie les dessins.

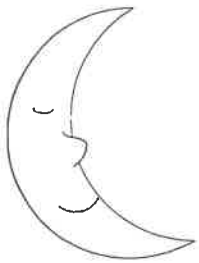

la lune



Nano



Line

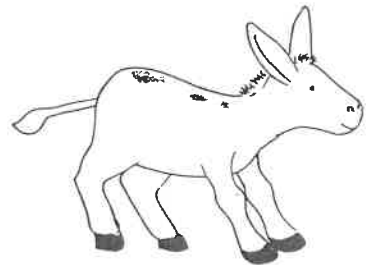

l'âne

5. Continue la frise.

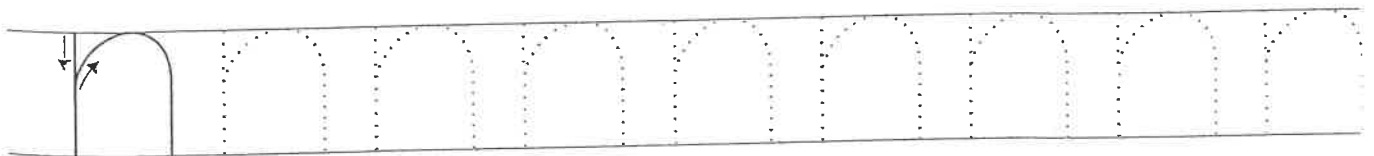

6. Reproduis la lettre n.

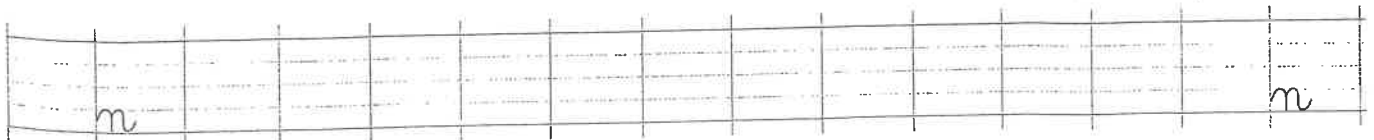

N n

n [n]

un âne

un âne

7. Entoure comme le modèle.

na la na ni na no a na nu na
 na na an na no a ni an no na

8. Entoure na dans les mots.

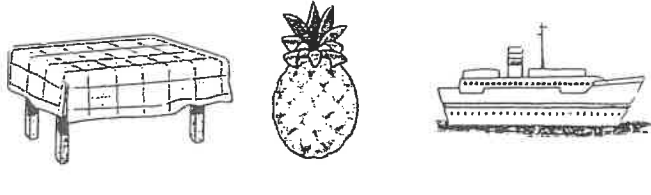

la nappe l'ananas le navire

Entoure ni dans les mots.



la niche le cornichon le nid

9. Attache les mots semblables.

- | | |
|-----------|-----------|
| Nano . | • la lune |
| la lune . | • l'âne |
| l'âne . | • Nano |

10. Écris le mot qui correspond au dessin.

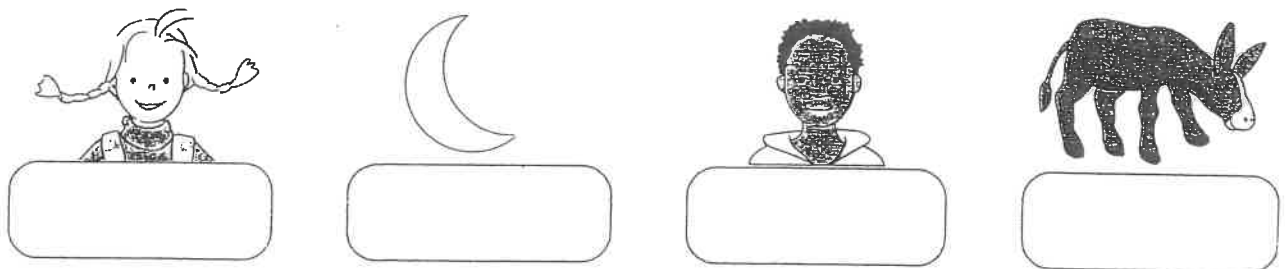

11. Colorie le dessin qui correspond au son de l'étiquette.

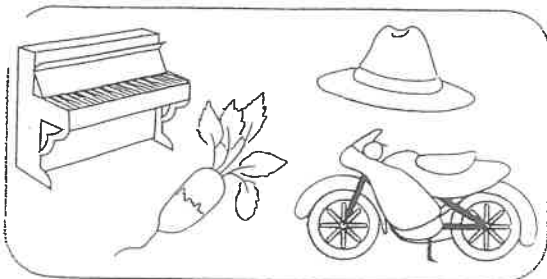

J'entends le son [no].

J'entends le son [ne].

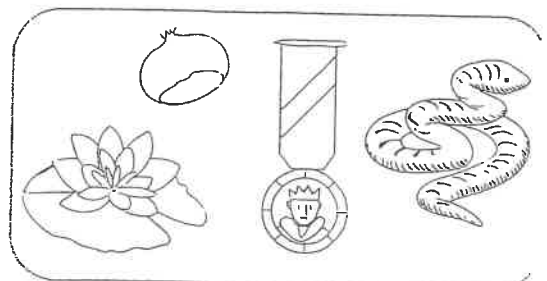



N n n [n]

12. Nomme chaque dessin. Colorie de la bonne couleur.

né nê ni no nu

13. Colorie le dessin quand tu entends le son [n].

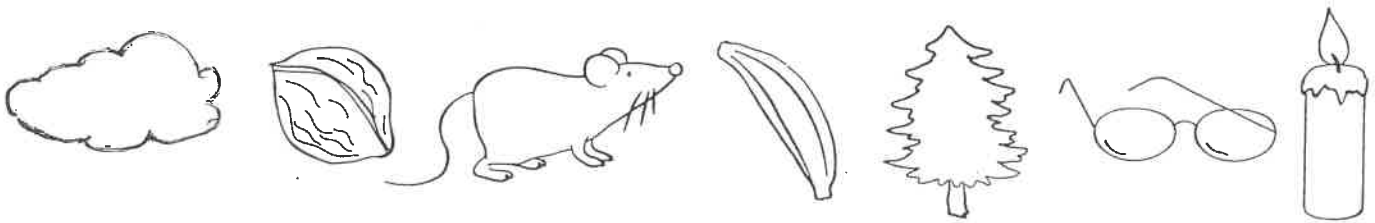

14. Colorie les ronds des syllabes dictées.

na no lo ni né lé nu la

15. Reproduis.

l'âne l'âne

16. Complète les mots avec n, i ou o.

.....la Lil..... Nan..... L.....ne

17. Complète le mot avec la bonne syllabe : na, ne, ni, no, nu.

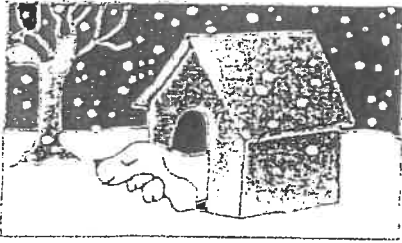

la ...che

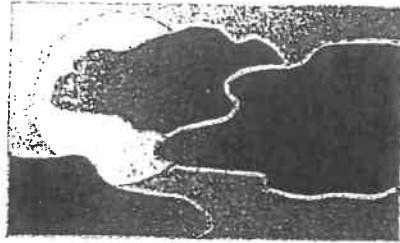

le ...age

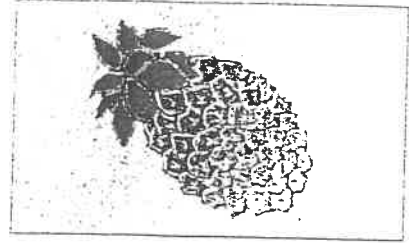

l'a...nas

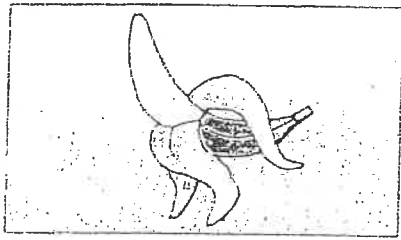

la ba...ne

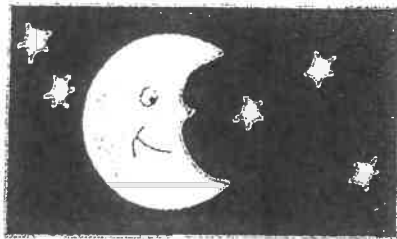

la lu....



led

18. Écris les syllabes dans le bon ordre pour former un mot.

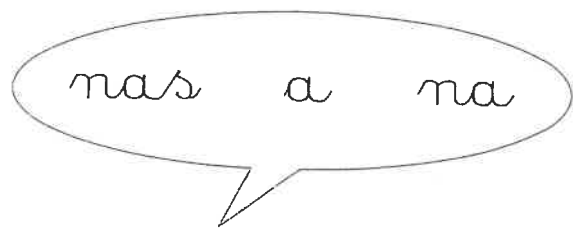
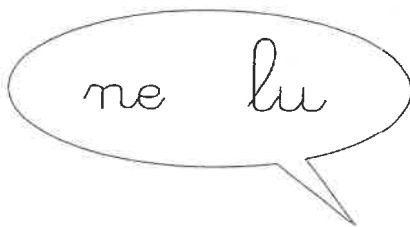

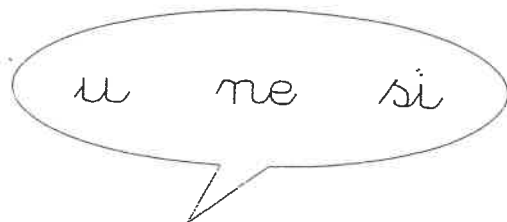
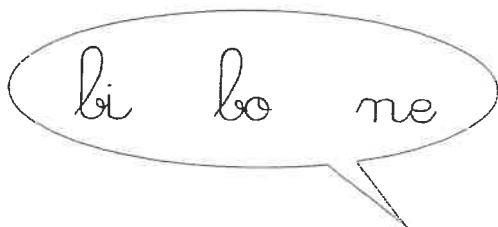

19.



Colorie les n n en vert.



Je suis le numéro ...

n	n	n	n	n	n	n	n	n	n	n	n	n	n	n	n
n	n	u	u	m	n	n	u	n	n	u	n	n	n	m	n
n	n	m	n	n	n	n	n	n	n	n	u	n	m	n	n
n	n	u	m	u	n	n	m	n	n	n	n	m	n	n	n
n	n	n	n	m	n	n	u	n	n	n	u	n	m	n	n
n	n	u	m	u	n	n	m	n	n	m	n	n	n	u	n
n	n	n	n	n	n	n	n	n	n	n	n	n	n	n	n

20. Invente une phrase avec les mots suivants.
Tu peux choisir ...

⚠ Tu dois utiliser au moins 3 mots de la liste.

maman - le renard - la lune - un âne -
la nappe - le piano - un domino -
le nuage - la banane - Noémie - Nicolas -
Marine -

Prénom : _____

Date : _____

La lettre n- N - n - N°

Handwriting practice sheet for the letter 'n'. It consists of six rows of horizontal lines. The first row contains eight lowercase 'n's. The second row contains three lowercase 'n's followed by four dots. The third row contains two lowercase 'n's followed by four dots. The fourth row contains three uppercase 'N's. The fifth row contains one uppercase 'N' followed by four dots. The sixth row contains one uppercase 'N' followed by four dots.

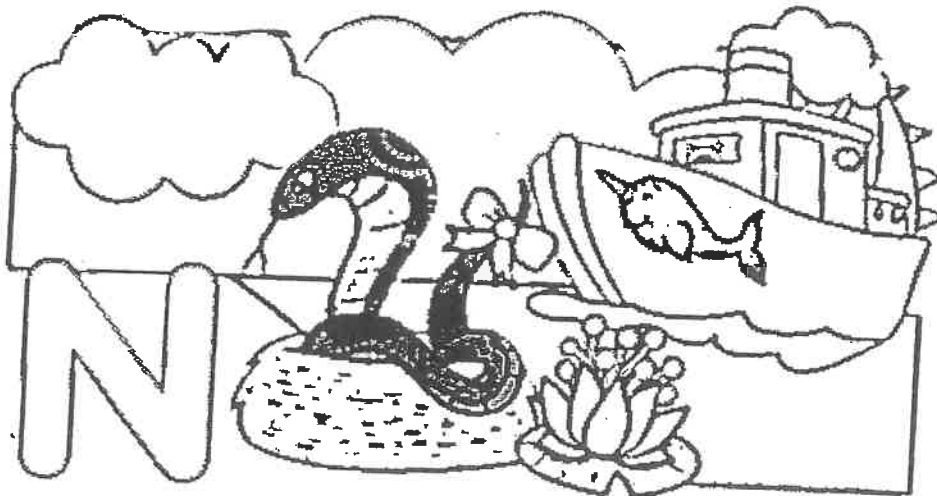

Nom :

Date :

1. Décomposer le nombre 10



Complète.

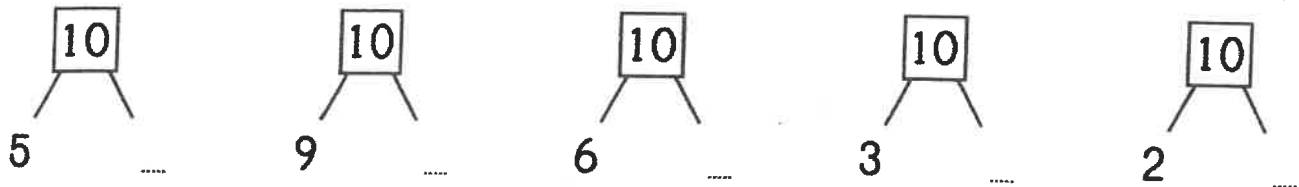

Complète.

$10 = 5 + \dots$	$10 - 5 = \dots$	$10 - \dots = 5$
$9 + \dots = \dots + 9$	$10 - 9 = \dots$	$10 - \dots = 9$
$6 + \dots = \dots + 6$	$10 - 6 = \dots$	$10 - \dots = 6$
$3 + \dots = \dots + 3$	$10 - 3 = \dots$	$10 - \dots = 3$
$2 + \dots = \dots + 2$	$10 - 2 = \dots$	$10 - \dots = 2$

2. Reconnaître les calculs

Entoure le calcul qui correspond au schème.

Calcule.

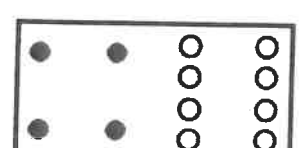
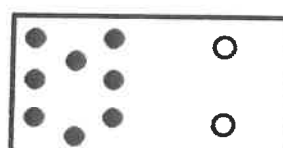
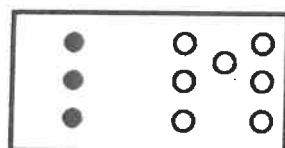
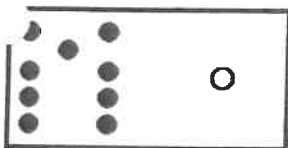

$10 - 1 = \dots$	$5 + 3 = \dots$	$3 + 5 = \dots$	$4 + 6 = \dots$
$8 + 2 = \dots$	$3 + 7 = \dots$	$10 - 2 = \dots$	$4 + 4 = \dots$
$9 + 1 = \dots$	$10 - 3 = \dots$	$8 + 2 = \dots$	$6 + 2 = \dots$
$9 - 1 = \dots$	$1 + 2 = \dots$	$8 - 2 = \dots$	$6 + 4 = \dots$
$10 - 9 = \dots$	$7 + 3 = \dots$	$2 + 8 = \dots$	$10 - 2 = \dots$
$10 + 1 = \dots$	$10 - 2 = \dots$	$10 - 1 = \dots$	$10 - 4 = \dots$
$1 + 9 = \dots$	$10 - 7 = \dots$	$10 - 8 = \dots$	$6 - 4 = \dots$
$5 + 5 = \dots$	$7 - 3 = \dots$	$10 - 3 = \dots$	$10 - 6 = \dots$

Nom :

Date :

Problèmes

1. Reconnaître le calcul.

Entoure le bon calcul.



$6 + 2 = \dots\dots$



$9 - 3 = \dots\dots$

$8 - 2 = \dots\dots$



$2 + 1 = \dots\dots$



$3 - 1 = \dots\dots$

$1 + 2 = \dots\dots$

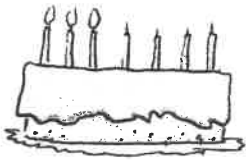

$5 + 2 = \dots\dots$

$7 - 4 = \dots\dots$

$1 + 6 = \dots\dots$

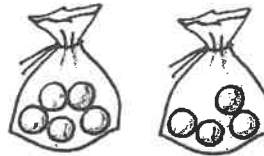

$3 + 6 = \dots\dots$

$5 + 4 = \dots\dots$

$4 + 5 = \dots\dots$



$3 + 3 = \dots\dots$

$2 + 2 + 2 = \dots\dots$

$6 - 2 = \dots\dots$

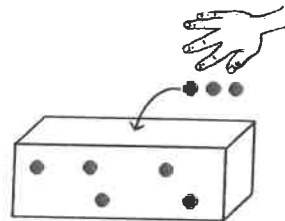

$4 + 4 = \dots\dots$

$5 + 3 = \dots\dots$

$8 - 5 = \dots\dots$

2. Calculer.

Complète.

Le facteur distribue le courrier.

Yasmine reçoit

en tout, elle reçoit :

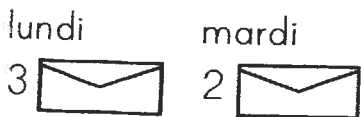

Calcul : + =

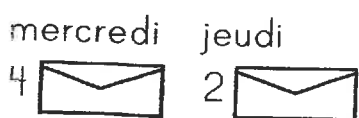

Calcul :

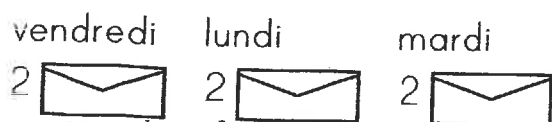

Calcul :



Vendredi 26 juin

Travail pour

les 7^{èmes} années

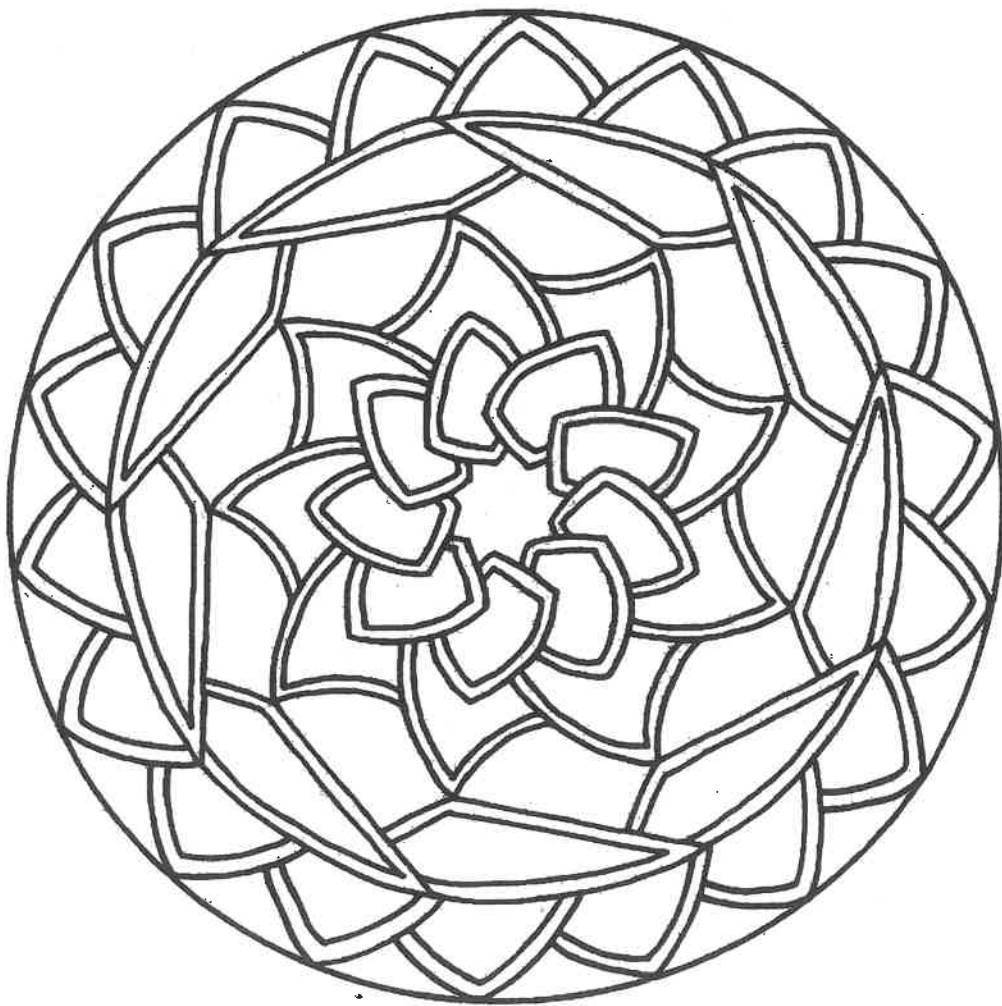

Programme de la journée du vendredi 26 juin.

1. Reprise des devoirs.
2. Lecture : Farde 53.
3. Calcul : Les dizaines : Le jeu des allumettes : manipulation, jeux et exercices.
4. Lecture : La lettre « n » : Exercices.
5. Ecriture : La lettre « n » : Copie.
6. Lecture : Compréhension à la lecture : « Dans le jardin ».
7. Calcul : Découverte de la notion de multiplication : « Je fais des tas » : Manipulation.
8. Lecture : « n » - « m » : Dossier.
9. Dessin : « Je dessine comment j'ai vécu le confinement » (prolongement du spectacle « Le tout petit monsieur ») (suite).
10. Journal de classe et explication des devoirs.

Devoirs pour le mardi 23 juin.

- Lecture : Terminer le dossier « n » - « m ».
- Lecture : Farde 52 - 53.
- Apporter un jeu calme.

Prénom : _____

Date : _____

Le jeu des allumettes.

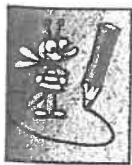







Entoure le matériel nécessaire pour former les nombres.

7		
14		
29		

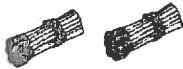



Écris les nombres représentés.

Entoure le matériel nécessaire pour former les nombres.

21		
10		
33		

Relie chaque nombre à sa représentation.

	•	•	11
	•	•	8
	•	•	23

Prénom : _____



Date : _____

La lettre n.

1. Colorie chaque fois que tu entends « n ».

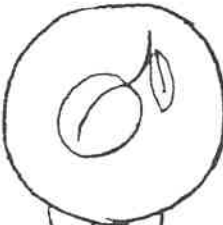
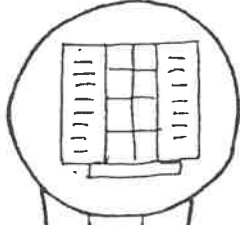
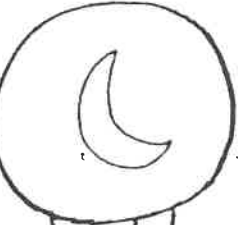
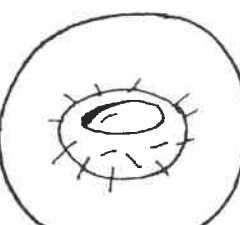
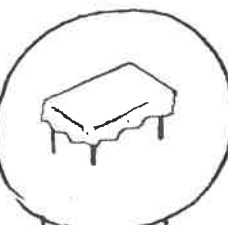
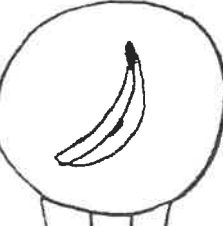
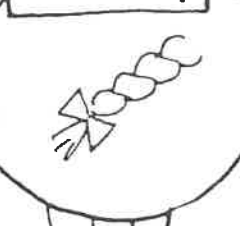
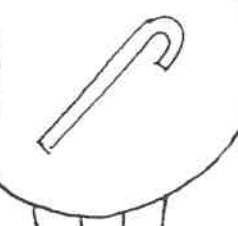
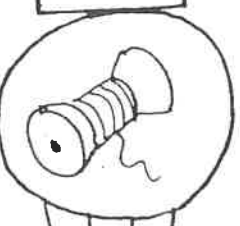

2. Barre le mot menteur.

 brune prune	 fenêtre ténèbres	 nul lune	 nid dîne	 panne nappe
 panade banane	 natte note	 canne Anne	 babine bobine	 il tonne il donne

Entraîne-toi à écrire...

Léonie donne une banane à Lou.

Valentin lave la moto jaune.

Simon joue au ballon.

Noah ne va pas à l'école.

Compréhension à la lecture.

1. Je lis 2 fois le texte.

Dans le jardin.

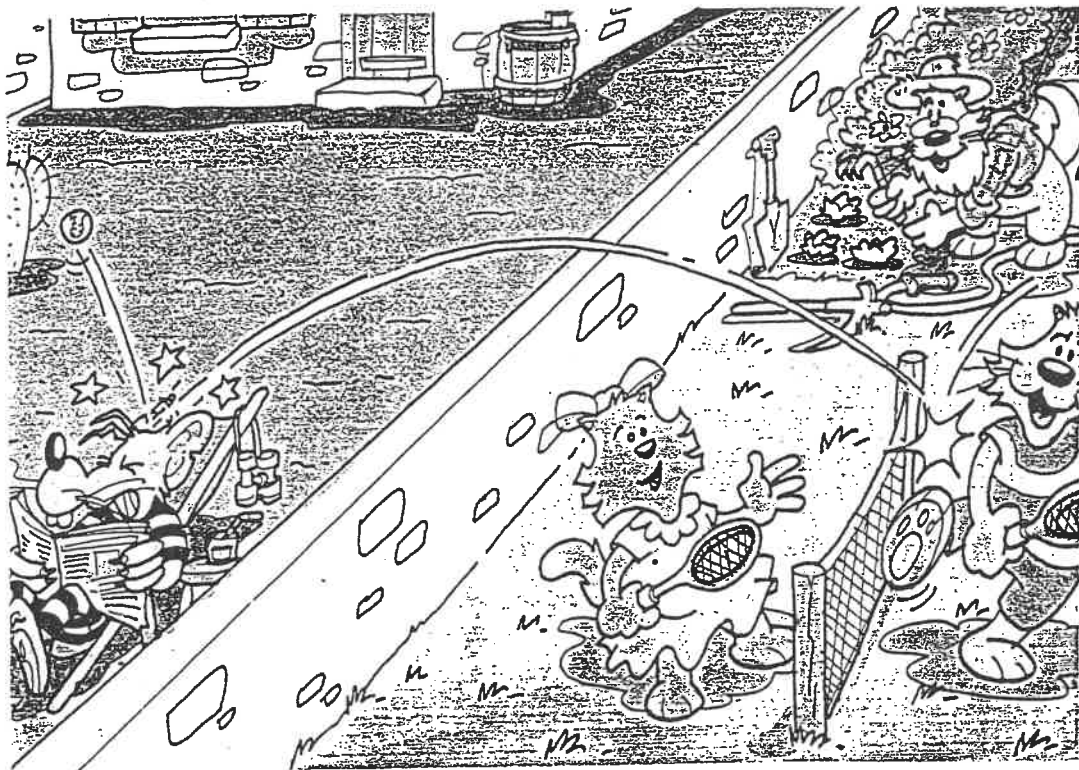

Marou joue avec Mina dans le jardin.

Marou a joué fort !

La balle tombe juste sur la tête de Ratus
qui lit son journal en pyjama.



2. Je comprends ce que je lis.

Vrai V ou Faux F

1. C'est Marou qui joue avec Mina. _____
2. C'est Mina qui a une jolie jupe. _____
3. Je joue avec Mina ! dit Ratus. _____
4. C'est Ratus qui a mis un pyjama. _____
5. Qui est dans le jardin ? C'est Belo. _____
6. Qui lit le journal ? C'est le rat vert. _____
7. Je joue dans le jardin, dit Ratus. _____

3. J'écris.

Mina a une jolie jupe.

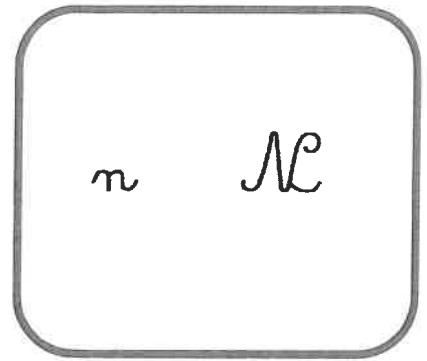

Un âne

Un âne

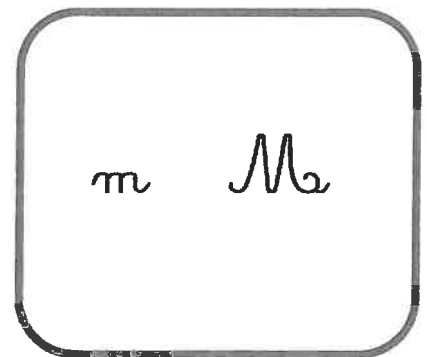

Le fantôme

Le fantôme

Prénom : _____

Date : _____

Colorie si tu entends n.

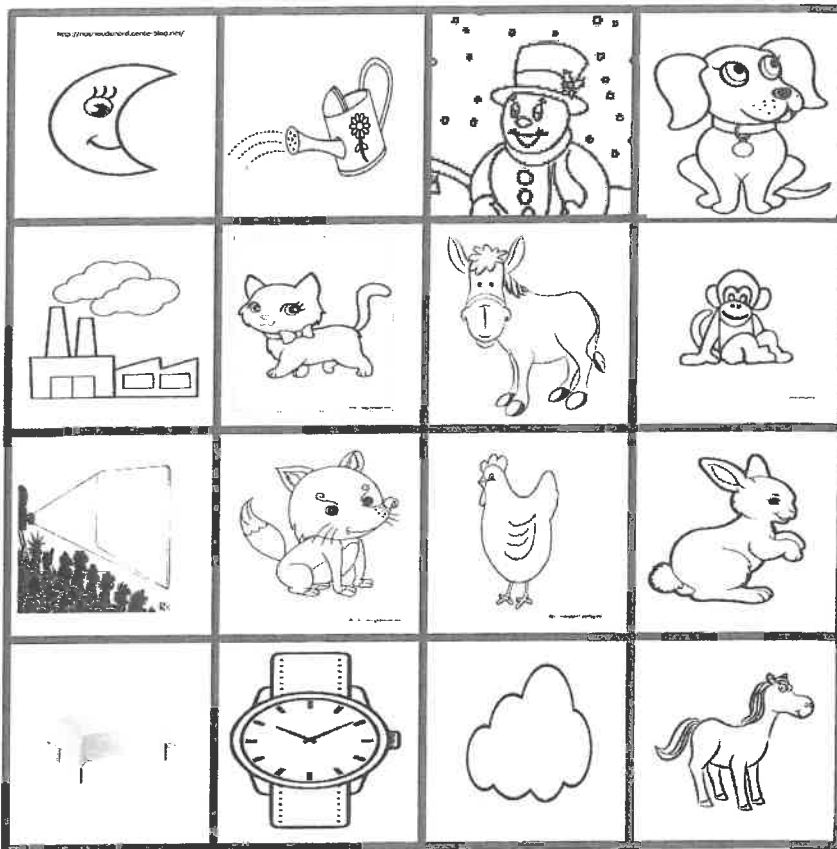

Choisis le bon mot. Entoure-le.

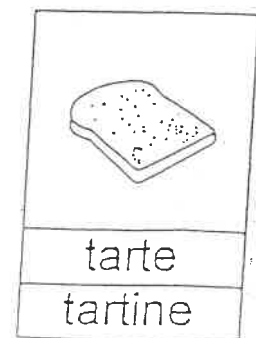
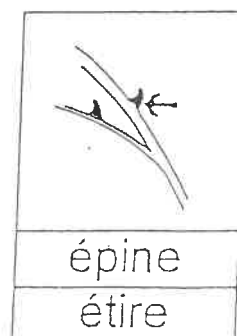
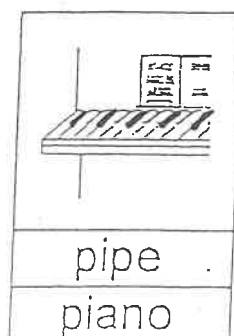
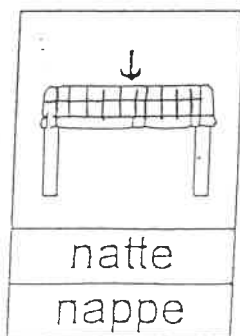

Relie.

piano

tartine

un

panade

ananas

une

renard

limonade

nappe

numéro

Trouve et recopie le mot.

lune tartine ananas piano âne

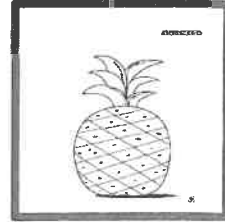
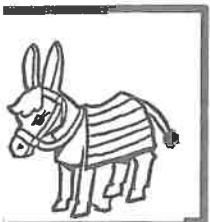

Relie le dessin au bon mot.



lune

âne

lit

nid

navire

numéro

os

mur

ananas

livre

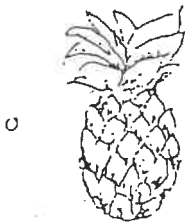
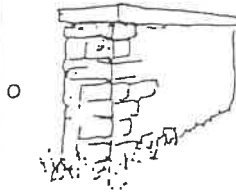
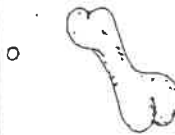
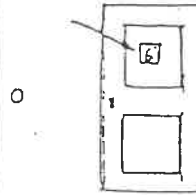

Complète les mots.

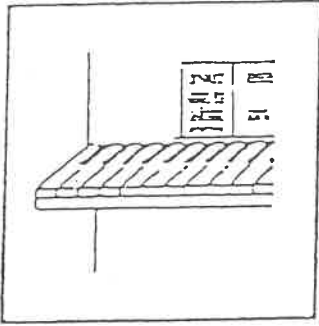

le pia ..

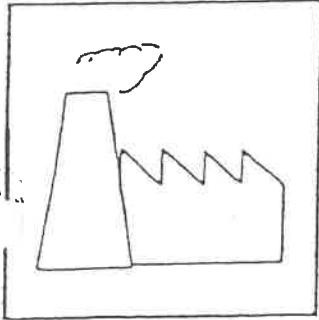

une usi ..

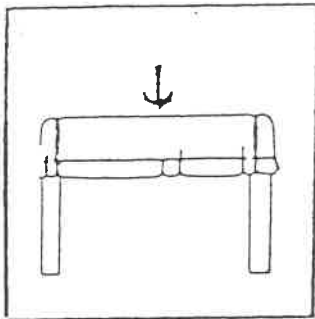

la .. ppe

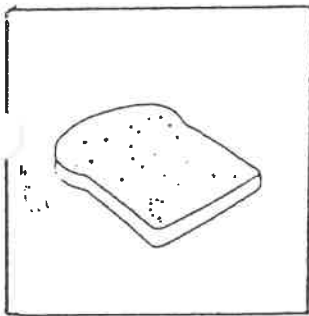

la tarti ..

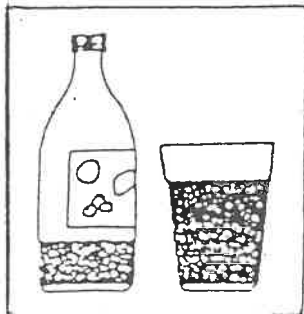

la limo .. de

Recopie les syllabes dans l'ordre.



ne lu



ne a

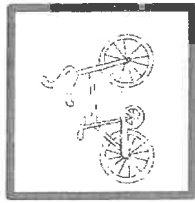

lo vé



me la

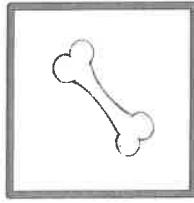

os

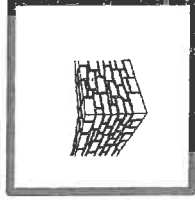

mur

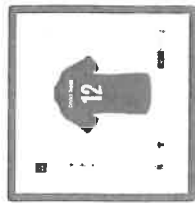

me ro tu

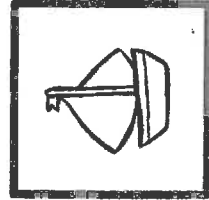

vi re na

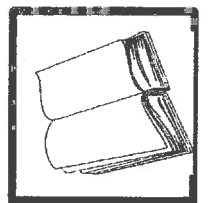

li ve



a nas na *

Complète les phrases avec les mots proposés.

n

Le navire Eline vitrine une banane les pavés

Elena a vu une robe dans la _____.

Anna donne _____ à Denis.

_____ arrive dans le port.

L'âne trotte sur _____.

_____ apporte le panier de fruits.

Colorie le mot caché.

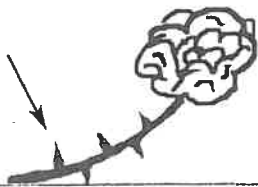

épine

népimeipunépinetinepinat

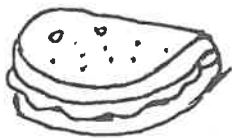

tartine

tardinefatartinetartefarine



bonnet

abonnébommetdonbonnetdom



panier

napaniepanierapiepiqanierpan

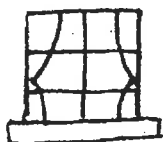

fenêtre

tefenetrefemêtrerefenêtrerefêtre

Ecris m ou n dans la case.

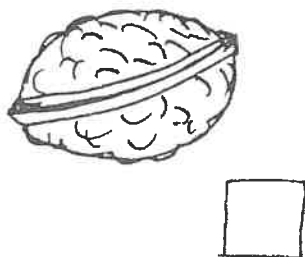
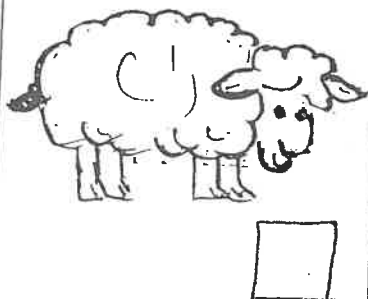
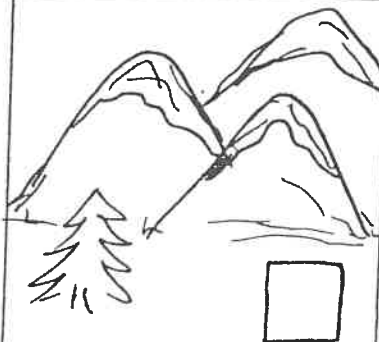
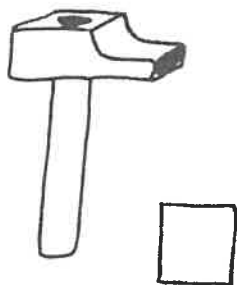
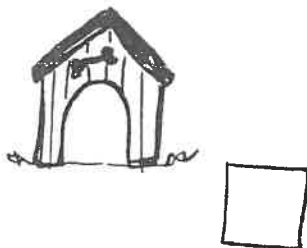
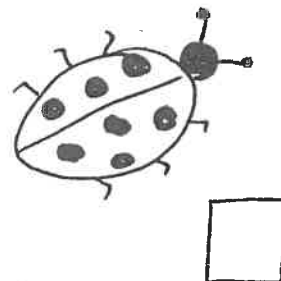
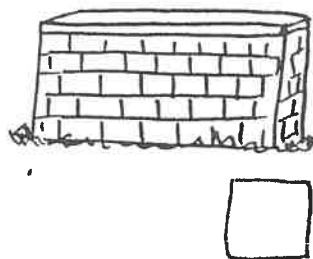
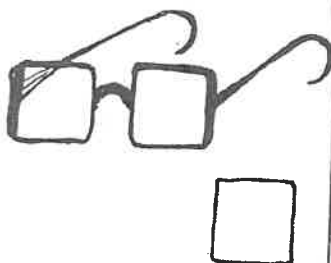
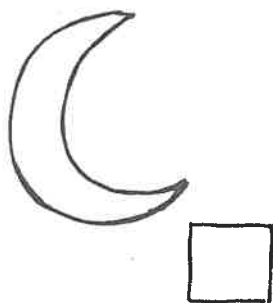
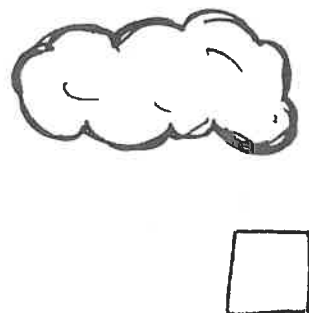
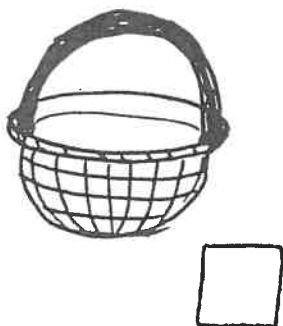
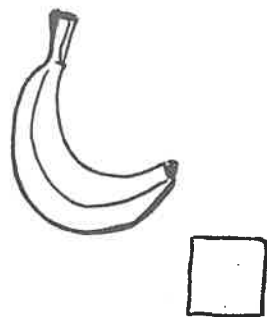
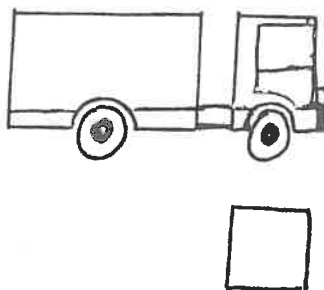
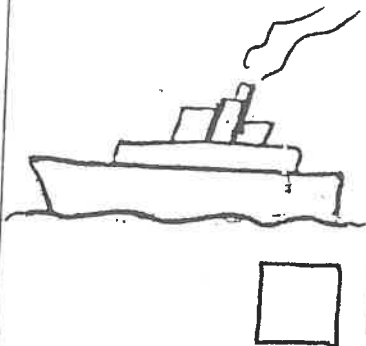

Chatouille veut jouer au foot. Aide-le à trouver son ballon en coloriant les cases dans lesquelles tu vois « m ».

m

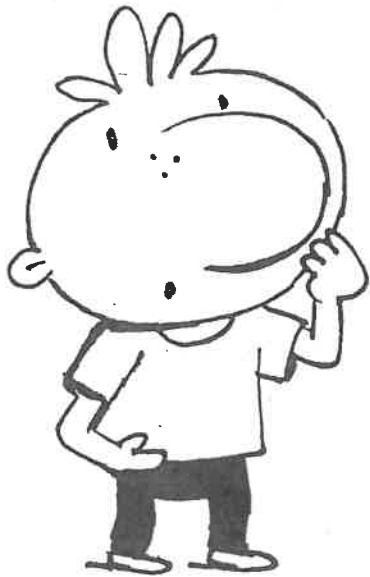

pont	amie	plume	musique	dans
Marie	rame	banane	moka	âne
crème	cabane	donner	pomme	mur
lune	savane	Anne	nuage	

Ajoute les syllabes qui conviennent.



.. rin

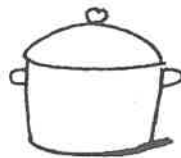

mar.. te

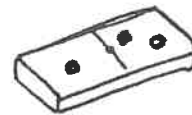

do .. no

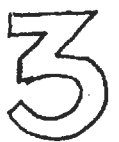

nu .. ro



che.. se

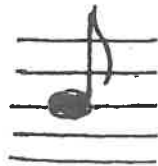

.. te



ba ..

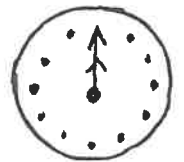

.. di



du ..



plu ..



.. to



.. age

Recopie les syllabes dans l'ordre et relie le mot au dessin.

m

ma to
te

Handwriting practice lines for the word 'matote'.

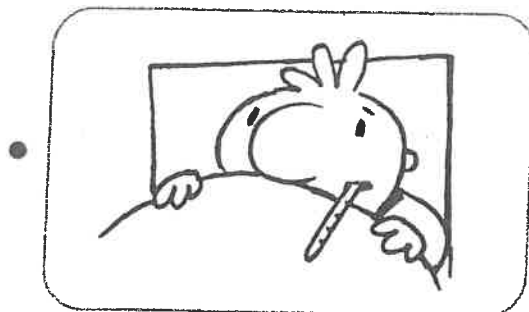

le bi
mo

Handwriting practice lines for the word 'le bimob'.

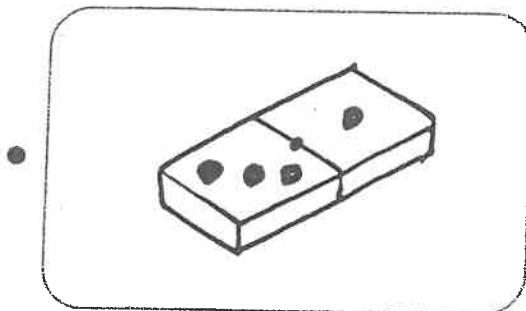

vi re
na

Handwriting practice lines for the word 'virena'.

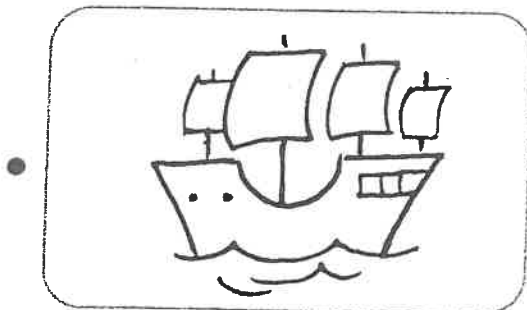

mi no
do

Handwriting practice lines for the word 'minodo'.

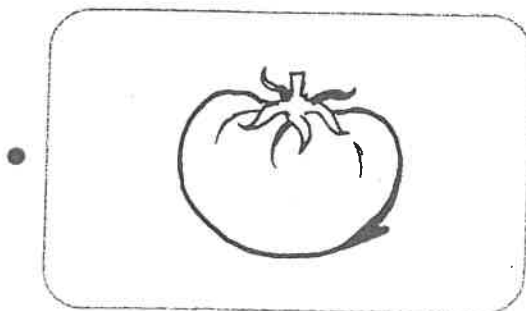

ma de
la

Handwriting practice lines for the word 'madela'.

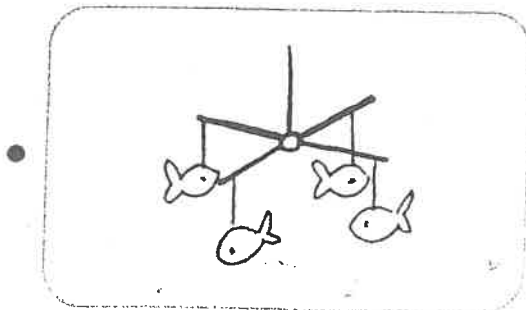

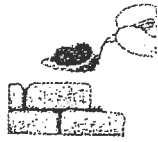

Je construis des mots.

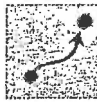
1.  Relie un ou une au dessin.

un
une

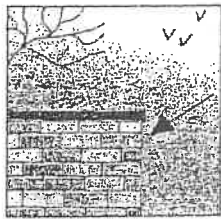

un
une

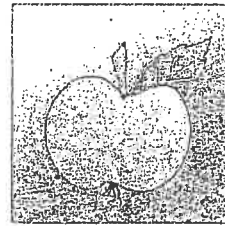

un
une



un
une

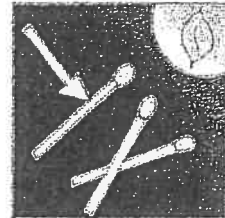

un
une

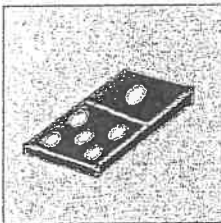

un
une

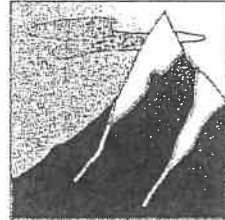

2.  Écris un ou une devant le mot.

..... maman



..... voiture



..... noeud



..... poupée



..... sapin



..... guirlande



..... boule



..... cadeau



..... pomme



..... peinture

